

Neon® Multi

Measuring disinfectants, pH, temperature, opt. ORP or conductivity and/or Total Chlorine

Multi channel water monitoring instrument

Neon® Multi is a leading edge measuring and control instrument. Its range of functions can be tailored according to customers' applications.

The entry level version is equipped with 3 measurements: disinfectant, pH and temperature. Additionally, Redox, a 5th measurement (Total Chlorine or conductivity) can be added or the 6th input can be used for Total Chlorine measurement (Zirkon® DIS Total).

Neon® Multi's water measurement process can be controlled at any time, from any place, on any device via Kuntze's Cloud Connect® service. All Kuntze products are Made in Germany.



Applications



Process Water



Disinfection



Drinking Water



Food & Beverage



Waste Water Treatment



Pool & Spa

CLEAR. CONTROL. CONNECT.

Neon® Multi

Technical data

Measuring range

| | | |
|----------------------------------------------------|--------------------------------------------------|--------------------------------------------|
| Disinfection (DIS 1) | Free Chlorine, Chlorine Dioxide, Total Chlorine: | Up to 1000 µg/l, 5.00 / 10.00 / 20.00 mg/l |
| | Ozone: | Up to 1000 µg/l, 5.00 / 10.00 mg/l |
| | Hydrogen Peroxide: | Up to 30.00 mg/l |
| pH | | 0.. 14.00 pH |
| Temperature | | 0.. 50.0 °C (32.. 122 °F) |
| ORP (optional) | | 1500.. + 1500 mV |
| 5 th measuring input (optional) | Conductivity: | Up to 2.000, 20.00, 200.0, 500,0 mS/cm |
| 6 th measuring input (optional) (DIS 2) | Free Chlorine, Total Chlorine: | Up to 1000 µg/l, 5.00 / 10.00 / 20.00 mg/l |

Input characteristics

| | | |
|------------------------------|-----------------------------------------------------------------------------------------------------------------------------|-----------------------------------------------------------------------------------------------------------------|
| Limit of Detection DIS | +/- 2 % from measuring range end (except Hydrogen Peroxide) | |
| Temperature measuring range | 0..50 °C (32.. 122 °F) | |
| Temperature compensation | 0.0.. 8.0 %/K, adjustable coefficient (DIS), nonlinear (pH) | |
| pH compensation | Nonlinear (DIS) | |
| Digital input | Flow control, external controller stop, 2 x level control, activation 2nd or 3 rd control parameter set, leakage | |
| Process conditions chemistry | pH-range: | 6.. 8 pH (Free Chlorine) 6.. 9 pH (Chlorine Dioxide, Ozone, Hydrogen Peroxide) 6.. 10 pH (Total Chlorine) |
| Process conditions assembly | Min. conductivity: | Depending on sensor |
| | Flow Input: | > 0.5 bar, >30 l/h |
| | Flow Output after Stabiflow®: | ~ 30 l/h |
| | Temperature: | 0.. 50 °C |
| | Pressure: | < 6 bar at 20°C |

Output characteristics

| | | |
|------------------|-------------------------------------------------------------|-------------------------------------|
| Alarm relay | Up to 4 potential free CO, max. 250 V; 2 A, 550 VA | |
| Output signal | Optional: 5 x 0/4.. 20 mA (scalable, galvanically isolated) | |
| | Load: | Max. 500 Ohm |
| | Registration range: | Scalable within the measuring range |
| Storage media | SD card up to 1 GB: | Industry standard |
| Serial interface | Option: | RS 485 Modbus RTU |
| | Baud rate: | 19200 kbs (Modbus) |
| | Data format: | 8 bit |

Power supply

| | |
|-------------------|-------------------------------------------------|
| Line voltage | 85.. 265 V AC / DC, 50.. 60 Hz; Option: 24 V DC |
| Power consumption | 10 VA |

Process conditions

| | | |
|--------------------|----------------------------------------|----------------------------------------------------------------------------|
| Temperature | Storage: | -20 °.. +65 °C (-4 °..149 °F) Exception sensor: 0..+30 °C (32 °..86 °F) |
| | Operation: | 0 °.. +50 °C (32 °.. 122 °F) |
| Humidity | Max. 90 % rH at 40 °C (non-condensing) | |
| Ingress Protection | Wall mounted: | IP 65 |

Controller

| | |
|-----------------------|------------------------------------------------------------------------------------------------------------------------------------------------------------------------------------|
| Control parameter | Desinfection (ClO ₂ , Cl ₂ , O ₃ , H ₂ O ₂ , TCL), pH and other parameter optional |
| Control response | On / off controller (adjustable hysteresis) P / PI / PID controller (pulse-pause, pulse-frequency or continuous output) 3-point controller with or without position feedback |
| Relay | 4 relays, each a potential-free CO contact, max. 250 V, 2A, 550 VA |
| Start delay | 0.. 200 sec till controller activation |
| Digital input | See input characteristics |
| Control parameter set | 2nd and optional 3rd parameter set for night operation etc. |

Language

| | |
|------------------|-------------------------------------------------|
| Default language | English, German |
| Other options | Russian, Danish, Dutch, French, Polish, Spanish |

Certificates and approvals

| | |
|-----------|---------------------------------------------------------------------------------------------------------------------------------------|
| CE-Symbol | The product meets the requirements of the harmonized European standards and complies with the legal requirements of the EC directives |
| EMC | EN 61000 6-1 (3) EN 61000 6-2 (4) EN 61326-1 |

Design configuration

| | | |
|------------|--------------------------------------------------------------------------------------------------------------|--------------------------------------------------------------------------------------------------------------------------------------------------------------------------------------------|
| Material | Board: Assembly: Instrument (housing): Sensor: | PVC PVC ABS Glass, Plastic / Gold / Platin |
| Dimensions | 700 x 400 mm | |
| Weight | Approx. 1.9 kg | |
| Connection | Cable inlet: Plug-in terminal: Relays / power supply: Distribution block: Water hose connection: | 6 x M16, 10 x M12 Rigid / flexible 0.14 - 1.5 mm ² Rigid / flexible 0.2-1 / 0.2 - 1.5 mm ² Rigid / flexible 0.5 - 1.5 / 0.5 - 1.5 mm ² DN 6/8 |

Mechanical drawing

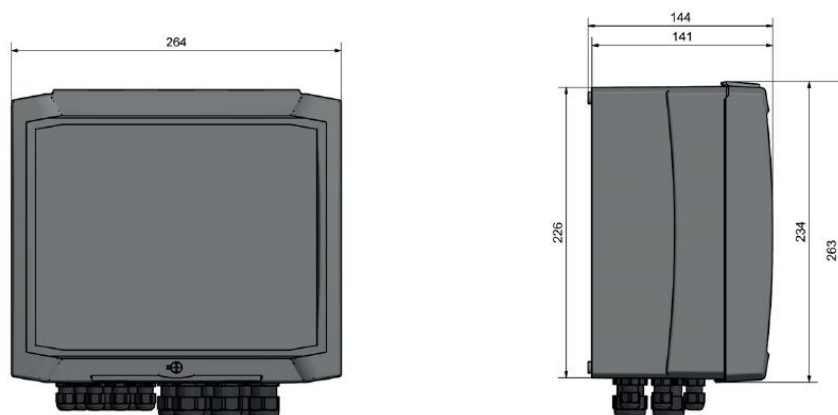

Interface diagram

