



**Remote-Control
made simple**

BL 2.0 M-PRO

BL 2.0 R-PRO



Aluminium casing with anti-acid coating and IP65 enclosure protection.

“Designed to suit the most critical applications with solid construction and a comprehensive control interface providing ease-of-process management”

OBL's new flexible solution for remotely controlling your Blackline 2.0 metering pump. High quality materials and enhanced user-friendly interface makes controlling your pump simple.

OBL We help grow your business



Modular

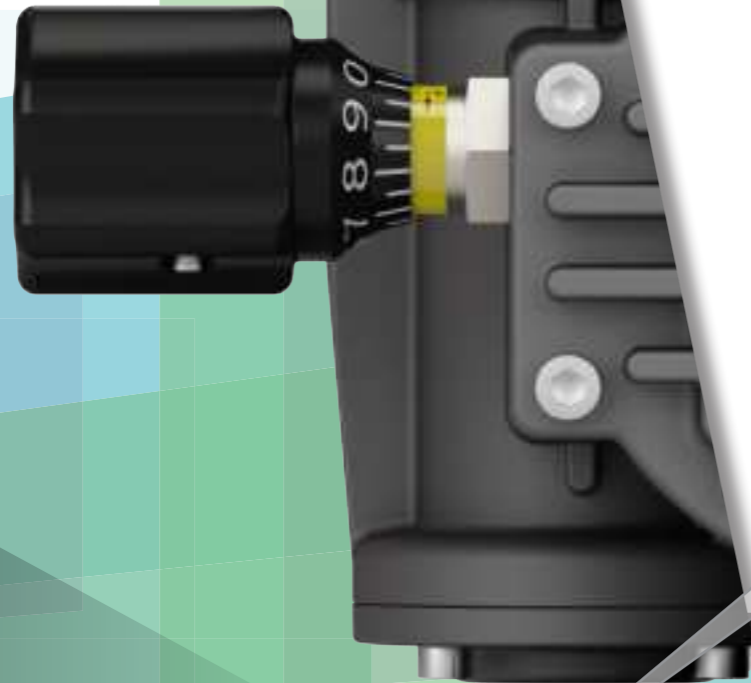

Improved ergonomics
Display positioned at
45° angle clear and
easy-to-read.

45°



Variable Gearbox
Orientation 0°-90°.

Versatile

Backwards compatible
unit, possible
installation on all
Blackline 2.0 models
M and **R** series.



Simple



10 different operating modes to fit any type of dosing application:

- 1 CONSTANT
- 2 BATCH
- 3 PAUSE-WORK
- 4 WEEKLY PROGRAM
- 5 ANALOG mA
- 6 ANALOG Volt
- 7 PPM
- 8 PAUSE-PERCENTAGE
- 9 MLQ (millilitres per quintal)
- 10 PULSE

Intuitive colour coded display messages:

BLUE Running

YELLOW Warning

RED Alarm

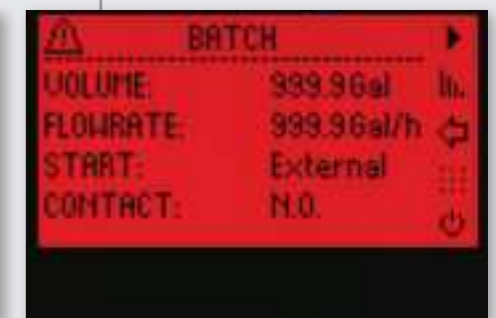

User friendly "JDS" Jog-dial-selector for easy menu navigation

Connections



- 1 **USB**
Host-statistics;
Diagnostics;
Configuration copy/backup;
Firmware updating
- 2 **LEVEL**
Two digital functions for "Full" and "low" level input
- 3 **PROXIMITY**
Stroke counter for mechanical alarm detection
- 4 **OUTPUT**
4-20mA output signal + relay signal management
- 5 **MODBUS**
Integrated RS485 module for MODBUS communication protocol
- 6 **INPUT**
Analog 4-20mA input (PLC; Flowmeter; pH probe) + 2 digital (ON/OFF and Pulse control)

Description

The Blackline PRO is based on OBL's proven mechanical diaphragm and plunger pump technology with the addition of a variable speed drive controller.

The unit comes with ten different operating modes, fully configurable, allowing you to fit the pump in any advanced pumping solution where the unit needs to be controlled remotely and automatically.

The Blackline PRO comes in a variety of flows and pressures as well as wet-end materials allowing you to find the best pumping solution for any application.

A full aluminium gearbox and control unit housing with antiacid EPD coating result in one of the most rugged and purposeful metering pumps on the market.

Form follows function: the angled backlit display and single jog dial element, make this an extremely versatile and simple to use metering pump.



Pump Head materials

M	PP	PP11	PP6	PP32	A	A112	A1121	A32	S562
PUMPHEAD	PP	PP	PP	PP	SS 316L	SS 316L	SS 316L	SS 316L	PVDF
DIAPHRAGM	PTFE	PTFE	PTFE	PTFE	PTFE	PTFE	PTFE	PTFE	PTFE
VALVE GUIDE	PP	PP	PP	PP	PP	PP	SS 316L	PP	PVDF
VALVE SEAT	PVC	SS 316L	PVC	INCOLOY-825	SS 316L	SS 316L	SS 316L	INCOLOY-825	PTFE
VALVE (BALL)	PYREX	SS 316L	PTFE	HASTELLOY C-276	SS 316L	SS 316L	SS 316L	HASTELLOY C-276	PYREX
VALVE HOUSING	PP	PP	PP	PP	SS 316L	SS 316L	SS 316L	SS 316L	PVDF
VALVE SEAL	FPM	FPM	FPM	FPM	FPM	PTFE	PTFE	FPM	PTFE
FLANGE	PVC	PVC	PVC	PVC	SS 316L	SS 316L	SS 316L	SS 316L	PVC

R	PAE	PCF	AAF	AAE	ACV	P	P11	A	A1121	AC	AC112	A-TL
PUMPHEAD	PVC	PVC	SS 316L	SS 316L	SS 316L	PVC	PVC	SS 316L	SS 316L	SS 316L	SS 316L	SS 316L
PLUNGER	SS 316L	CERAMIC	SS 316L	SS 316L	CERAMIC	CERAMIC	CERAMIC	SS 316L	SS 316L	CERAMIC	CERAMIC	SAF 2205
PLUNGER PACKING	EPDM	FPM	FPM	EPDM	VULKOLLAN	PTFE	PTFE	PTFE	PTFE	PTFE	PTFE	PTFE
VALVE GUIDE	PP	PP	PP	PP	PP	PP	PP	SS 316L	SS 316L	PP	PP	SS 316L
VALVE SEAT	SS 316L	PVC	SS 316L	SS 316L	PVC	PVC	SS 316L	SS 316L	SS 316L	SS 316L	SS 316L	SS 316L
VALVE (BALL)	SS 316L	PYREX	SS 316L	SS 316L	PYREX	PYREX	SS 316L	SS 316L	SS 316L	SS 316L	SS 316L	SS 316L
VALVE HOUSING	PP	PP	SS 316L	SS 316L	PYREX	PP	PP	SS 316L	SS 316L	SS 316L	SS 316L	SS 316L
VALVE SEAL	FPM	FPM	FPM	FPM	FPM	FPM	FPM	FPM	PTFE	FPM	PTFE	FPM
FLANGE	PVC	PVC	SS 316L	SS 316L	SS 316L	PVC	PVC	SS 316L	SS 316L	SS 316L	SS 316L	SS 316L

Overall dimensions

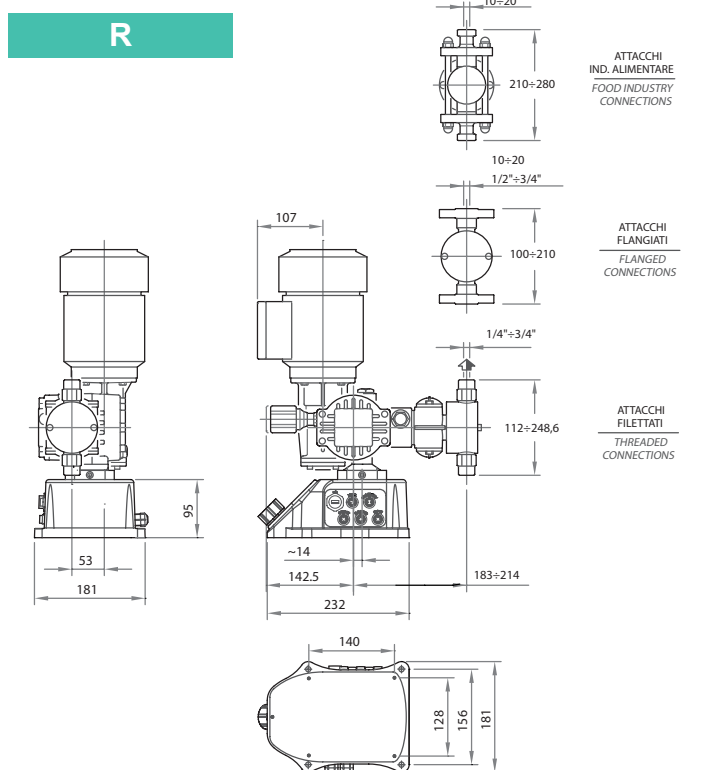
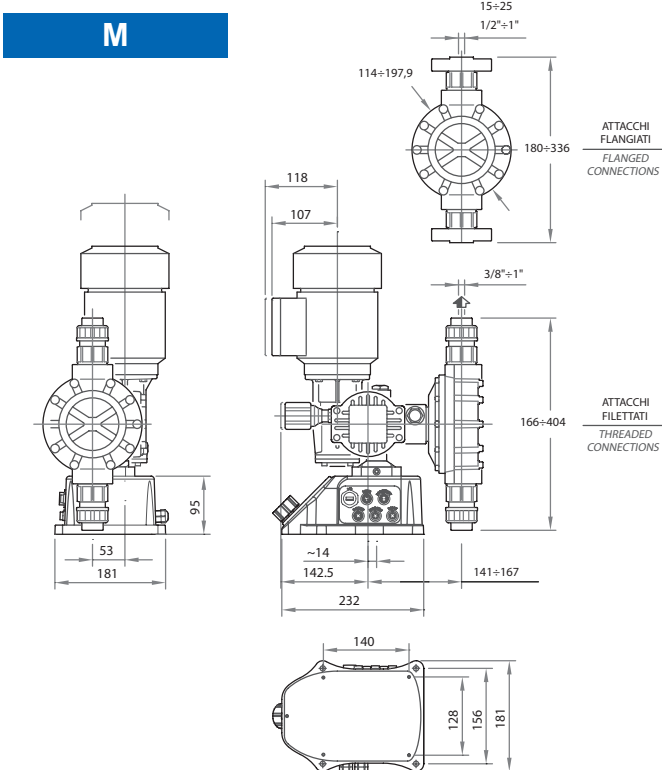

Technical data

M	R
---	---

		M	R
MECHANICAL DATA	Max. flow rate (@ 1,5 bar)	800 lt/hr	300 lt/hr
	Max pressure	12 bar	40 bar
	Max. stroke frequency	155 strokes/min	114 strokes/min
	Liquid temperature	-10°C +40°C	-10°+90°C
	Max. weight	28 Kg	26 Kg
	Precision	+/- 3%	+/- 3%
	Linearity	+/- 5%	+/- 3%
	Accuracy of repeatability	+/- 3%	+/- 3%
	Max. suction lift		2 m
	NPSHa		9,5 mt
	Turndown ratio		500:1
	Sound pressure (@ 1 mt)		<65 dbA
	Materials (actuator, casing, motor)		Aluminum
	Finishing (actuator, casing)		Electrophoretic deposition (EPD)
ELECTRICAL DATA	Max power consumption		750W
	Max. motor phase current		3,5 A
	Max. current absorption		6,5 A
	Power Supply		110 (-15%) V AC • 230 (+10%/-15%) V AC
	Frequency		50/60 Hz
	Operating temperature		-10/40 °C 14/113 °F
	Max inrush current		2,3A (110V) - 5A (230 V)
	Enclosure class (actuator only)		IP65
	Recommended fuse		6,3 x 32mm 8A
	USB	Type	
SERIAL	MODBUS		Half Duplex RS-485
	INPUT	4-20 mA	Input Voltage /Control input
Impedance			120 Ω
Pulse		Max load	28 V DC
		Max resistance in pulse circuit	15 KΩ
		Min pulse length	10ms
Remote		Max load START/STOP digital input	28 V DC
Level		Max load STOP digital input	28 V DC
	Max load START digital input	28 V DC	
OUTPUT	4-20 mA	Input Voltage /Control input	24 V DC
	Relays	Max load	24 V DC 3A

Performance

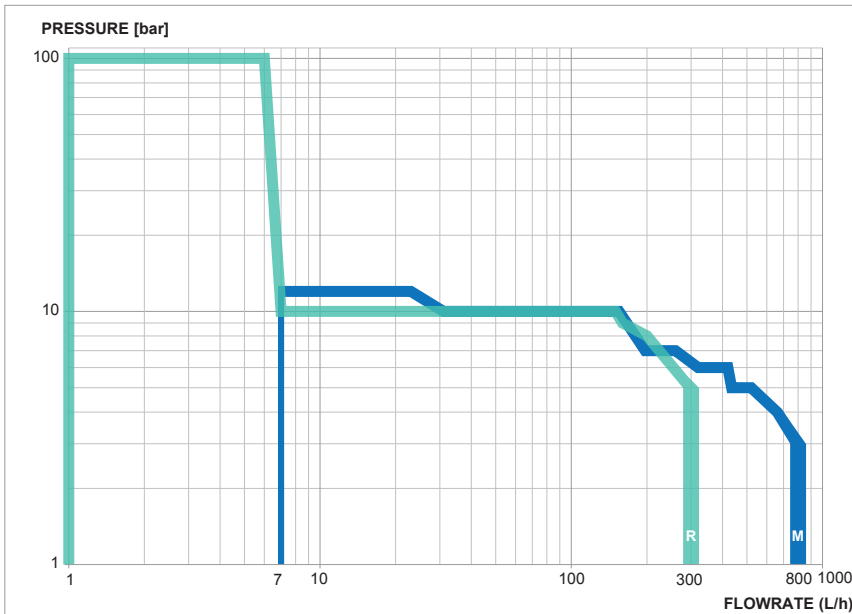

Kit PRO

Available for upgrading existing Blackline 2.0 M and R series pumps.

