



PRODUCT SPECIFICATIONS



MP3-2R

**Peristaltic Pump
With Speed
Adjustable Flow**

- Peristaltic Pump with Speed adjustable flow
- Small dimensions
- Easy installation and minimal maintenance
- PP box reinforced 30% talk
- IP 55 protection
- Automatic priming
- Security and reliability
- Polycarbonate front panel
- Wall mounting with stirrup
- Roller holder in PBT
- Rollers in Derlin (self lubricant)
- 2,5 mt power supply cable

OPTIONAL:

- Other Flowrates (Different than the standard indicated below)
- Different color (Microdos standard color is Blue)
- Pump Personalization (Logo Serigraph, Barcode, manuals)
- Extra Installation KIT, injection valves, Foot filters, tube fettings,...
- Hostaform Tube Connection Fettings (Food Applications)
- Low Level Switch sender

INSTALLATION KIT



For Detergent	Mounting Bracket	Injection Valve	Inj. Tube 2mt PVC	Suction Tube PVC	Foot Filter	
For Rinse-Aid	Mounting Bracket		Inj. Tube 2mt PE	Suction Tube PVC	Foot Filter	Tub Plug PP

TECHNICAL INFORMATION

CODE	Lt/h	ml/min	Bar	Rpm/min	Watt	Power	Inner Tube	Outer Tube
P04CM0301200	1	16,6	3	30	3,5	24VAC	Silicon	4x6
P04AM0104100	4	75	1	31	3,5	24VAC	Santoprene	4x6
P04AM0106100	6	95	1	40	3,5	24VAC	Santoprene	4x6
P04CA0301200	1	16,6	3	30	3,5	24VAC	Silicon	4x6
P04AA0104100	4	75	1	31	3,5	24VAC	Santoprene	4x6
P04AA0106100	6	95	1	40	3,5	24VAC	Santoprene	4x6

APPLICATIONS

- Chemical industries
- Laboratories and analysis
- Food industries
- Detergency
- Disinfection
- Swimming pools

PUMP VIEW (mm)

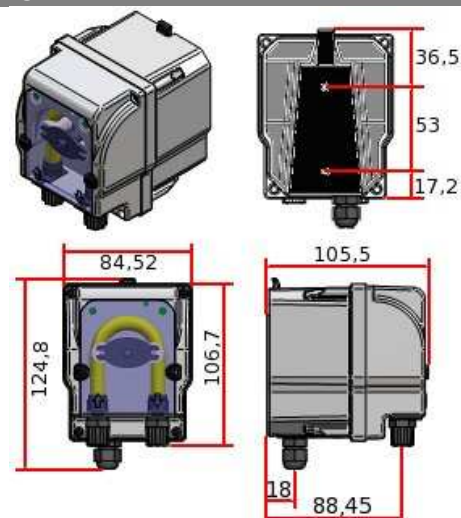

INSTALLATION EXAMPLES

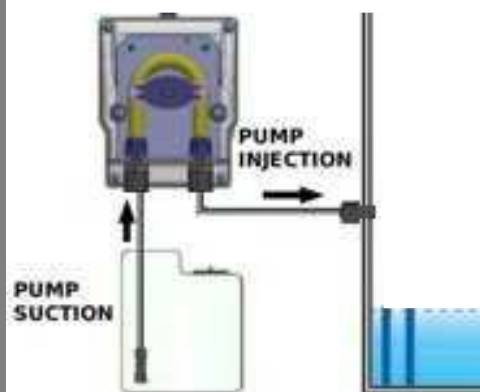

LIQUID ENDS

COMPONENT	STANDARD MATERIAL	OPTIONAL MATERIAL
INNER TUBE	SANTOPRENE /SILICON	
FETTINGS	POLYPROPYLENE	
Foot filter	AISI 316	
Injection valve	AISI 316-Viton	AISI 316-Dutral

PACKAGE (cm / Kg)

	KG
Pump: 12 x 18 x 12	0,90
Multipack (27Psz): 55 x 39 x 38	24,30
PUMPS/PALLET (216 Psz): 80x120x175	194,50

NOTES

- MADE IN ITALY
- 100% Tested before delivery
- Produced conform to CE laws