

# X9

series

*Process diaphragm metering pumps*

API 675 STD

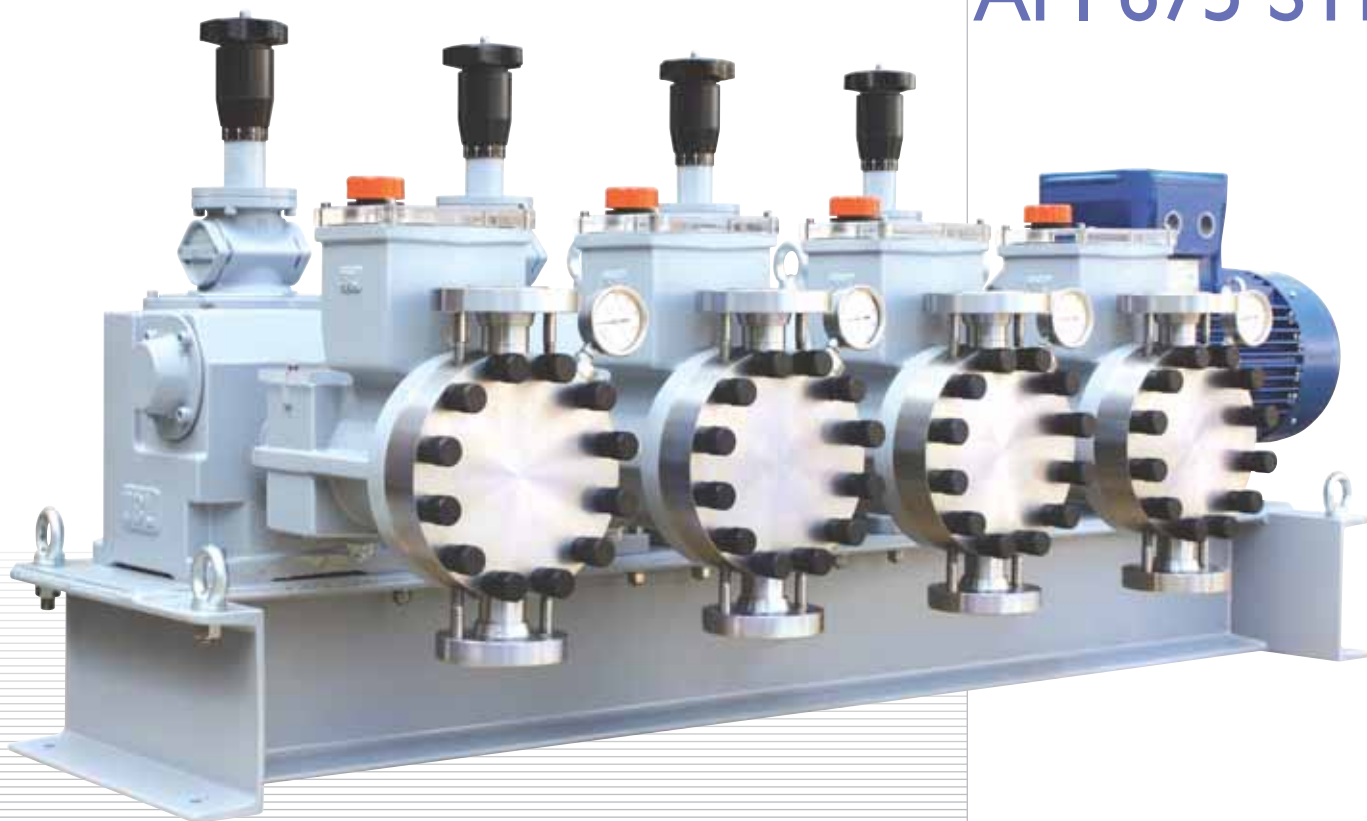

## X9 Process diaphragm metering pumps

X9 series OBL metering pumps, with as STD an innovative double diaphragm construction, are specifically designed for continuous demanding industrial applications.

Extreme reliability and durability are guaranteed by the positive return mechanism (full motion) and by the mechanically actuated replenishing valve (smart diaphragm) and built-in relief valve.

These pumps are supplied as STD with local visual diaphragm burst detector via pressure gauge. On demand, pressure switch and pressure transmitter for both safe and hazardous areas can be supplied. Oil-bathed sealless ceramic plunger guarantees low NPSH r and minimum maintenance.

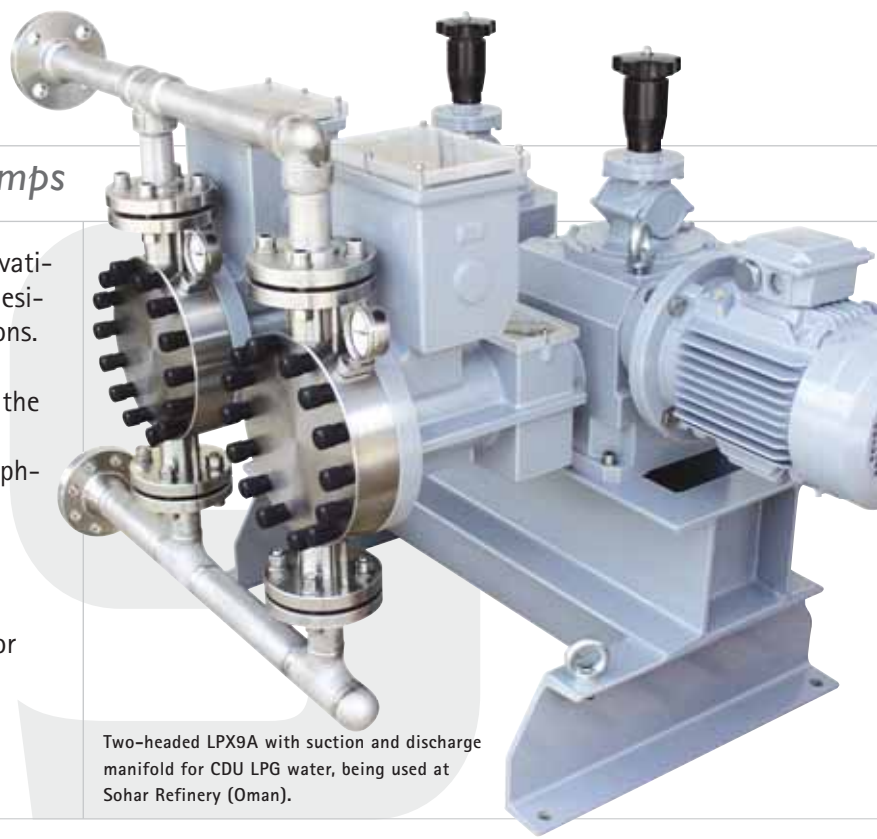

Two-headed LPX9A with suction and discharge manifold for CDU LPG water, being used at Sohar Refinery (Oman).

# X9

LPX9S with OBL designed ZC electrical actuator, being used at Ras Abu Fontas Power Plant (Qatar Electricity And Water).



Design and construction fully according to API675 STD guidelines 94/9 EG (ATEX).  
Certified GOST-R - RTN permit.

X9 pumps, can be equipped with Z type electrical actuator, with following characteristics:

- IP 66 STD
- Manual emergency override
- Anticondensation heater (on demand)
- Non standard voltages and frequencies
- External automatic/manual selector

Flow rate is adjusted according to following input signals:

- 4-20 mA, 0-20 mA, 20-4 mA and 0-10 V
- Pulses (0÷2 Hz - 0÷30 Hz)
- RS 485 protocol
- PROFIBUS DP



LYX9T (PTFE wetted parts with frontal AISI 316L shield) with OBL designed ZC electrical actuator, being used in Formosa Plastic Corporation (Taiwan).



**Typical X9 applications:**

- OIL&GAS
- CHEMICAL AND PETRO- CHEMICAL
- POWER STATION (boiler water & cooling water)
- FOOD INDUSTRY
- PULP&PAPER
- PLASTIC INDUSTRY
- REVERSE OSMOSIS



LNX9T (PTFE wetted parts with PTFE coated frontal AISI 316L shield) for organic acid solution, being used at Sankyo Chemical Toyo Eng. & Construction(China PR).



- Modular horizontal pumps combination with different sizes and strokes per minute (each pump has its own independent internal reduction gear), for pulse-less or different injection points.
- X9 STD pump head material include SS316L, PVC, PVDF and PTFE. Special construction with exotic materials on demand.
- X9 series conform to API 675 standard, meeting its constructional, design and performances requirements:
  - $\pm 1\%$  steady state accuracy within 10% and 100% of rated capacity.
  - $\pm 3\%$  repeatability and linearity within 10% and 100% of rated capacity.
- X9 series compliance to ATEX (94/9/CE), suitable for installation in group II, category 2 (zone 1/21) and group II category 3 (zone 2/22).
- Operating temp up to 100 °C with metallic wetted parts, higher temperatures on demand.



AISI 316L double diaphragm pump with all elastomers made of PTFE for methanol dosing ATEX pump, electrical motor and pneumatic actuator with manual emergency override, being used at Southern Water (UK).



<  
LPX9A with remote diaphragm rupture pressure indicator via IP65 pressure switch (ATEX II 2 G EEx-d IIC T6).

# LY X9 Technical data

TYPE	FLOW RATE l/h *	MAX PRESS. BAR	CONNECTIONS		kW
			THREADED	FLANGED	
LYC10	0,5	125	1/4" NPT F	1/2" ANSI	0,37
LY10	1,5	125	1/4" NPT F	1/2" ANSI	0,37
LY10	8	125	1/4" NPT F	1/2" ANSI	0,37
LY15	3	125	1/4" NPT F	1/2" ANSI	0,37
LY15	23	125	1/4" NPT F	1/2" ANSI	0,37
LY20	10	100	3/8" NPT F	1/2" ANSI	0,37
LY20	33	90	3/8" NPT F	1/2" ANSI	0,37
LY25	16	60	3/8" NPT F	1/2" ANSI	0,37
LY25	52	50	3/8" NPT F	1/2" ANSI	0,37
LY30	24	40	3/8" NPT F	1/2" ANSI	0,37
LY30	98	30	3/8" NPT F	1/2" ANSI	0,37
LY40	170	12	1/2" BSP F	1/2" ANSI	0,37
LY50	270	8	-	3/4" ANSI	0,37

\* Typical performances based on both 50 and 60 Hz.

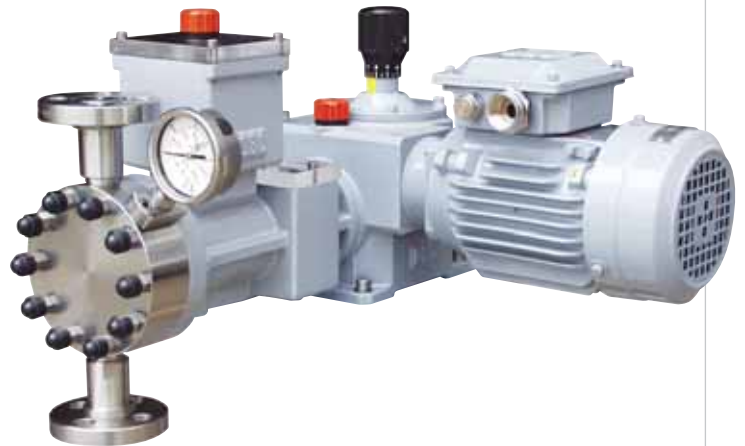

LY X9A series process diaphragm metering pump with AISI 316L pump head.



- Flow rates:**
  - Max flow rate **270 L/h**
- Motors:**
  - 0,37 kW
- Pump:**
  - Single and multiple
- Adjustment:**
  - Manual and automatic
- Casing material:**
  - Cast iron
- Stroke:**
  - 7,25 - 17 mm.
- Strokes/1':**
  - 25-36-50-70-95-100-118-145
- App. Weight:**
  - 30÷60 Kgs

## MATERIALS OF CONSTRUCTIONS

WETTED PARTS	X9 A		X9 P	
	LY 10-15	LY 20÷50	LY 10-15	LY 20÷50
LIQUID END	AISI 316L	AISI 316L	PVC	PVC
VALVE	RUBY	AISI 316L	RUBY	PIREX
VALVE SEAT	CERAMIC	AISI 316L	CERAMIC	PVC
VALVE GUIDE	AISI 316L	AISI 316L	PVC	PVC
VALVE SEAL	FPM	FPM	FPM	FPM
DIAPHRAGM	PTFE	PTFE	PTFE	PTFE

## MAX OVERALL DIMENSIONS

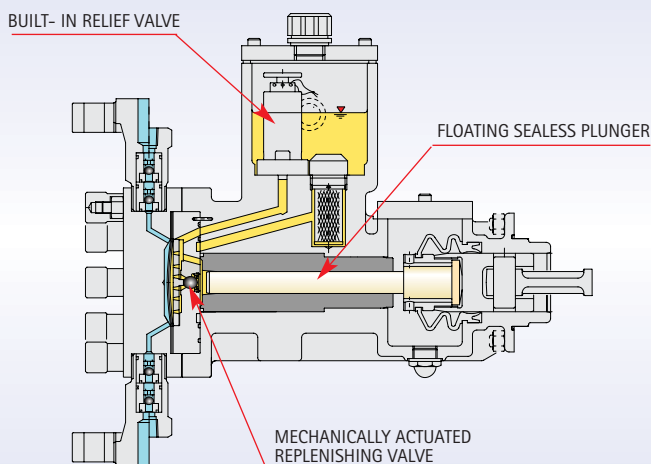
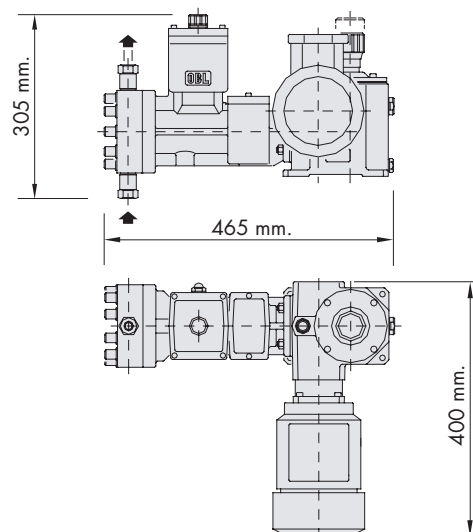

LY X9 type.

## LYH X9 Nodular cast iron

These pumps have same wetted material and design as standard LYX9.

LYHX9 pumps are supplied with nodular cast iron casing allowing both design temperatures below -30C° as well as installation of motor sizes up to size 90 - 1,5 kW.

LYHX9 casing also allows better pump installation, giving clearance and access area on the hydraulic side.

It is also available a LYHX9AA version with both casing and hydraulic chamber made in nodular cast iron, fully meeting more stringent material specifications than API 675 STD.

These pumps are realised with double metallic diaphragm only (AISI 316L) allowing internal PVS setting up to 150 bar g.

These pumps are specifically designed for continuous dosing of extremely low flow rates with operating pressure up to 125 bar g (down to addition rates of 100 millilitres per hour at 125 bar g operating pressure).



LYHX9 with AISI 316L: pump head being used in Kashagan Field Development (Agip Kazakhstan North Caspian Operating Company), equipped with pneumatic servo with I/P converter and diaphragm rupture detector via pressure transmitter.



- Flow rates:** • Max flow rate **270 L/h**
- Motors:** • 0,37 kW - 0,75 kW - 1,5 kW
- Pump:** • Single and multiple
- Adjustment:** • Manual and automatic
- Casing material:** • Nodular cast iron
- Stroke:** • 7,25 - 17 mm.
- Strokes/1':** • 25-36-50-70-95-100-118-145
- App. Weigth:** • 30÷60 Kgs

### MATERIALS OF CONSTRUCTIONS

WETTED PARTS	X9AA	X9 A		X9 P	
		LY 10-15	LY 20÷50	LY 10-15	LY 20÷50
LIQUID END	AISI 316L	AISI 316L	AISI 316L	PVC	PVC
VALVE	RUBY	RUBY	AISI 316L	RUBY	PIREX
VALVE SEAT	CERAMIC	CERAMIC	AISI 316L	CERAMIC	PVC
VALVE GUIDE	AISI 316L	AISI 316L	AISI 316L	PVC	PVC
VALVE SEAL	FPM	FPM	FPM	FPM	FPM
DIAPHRAGM	AISI 316L	PTFE	PTFE	PTFE	PTFE

### MAX OVERALL DIMENSIONS

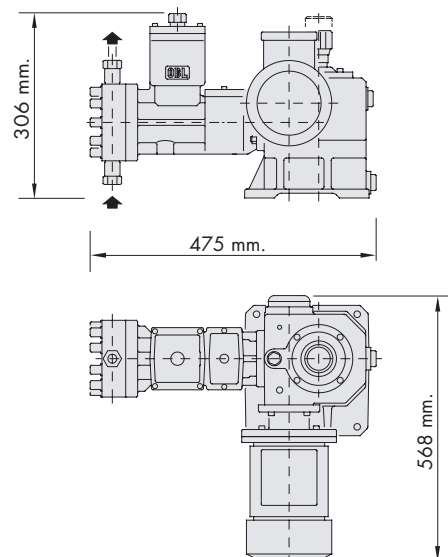

Pump LYHX9AA: with metallic double diaphragm and rupture detector via pressure gauge and manifold preset for upgrading (installation of pressure switch or pressure transmitter at customer's care).



# LK X9 *Technical data*

TYPE	FLOW RATE l/h *	MAX PRESS. BAR	CONNECTIONS	kW
LK30	49	70	1/2" ANSI	0,75
LK30	143	43	1/2" ANSI	0,75
LK40	87	40	3/4" ANSI	0,75
LK40	211	28	3/4" ANSI	0,75
LK50	137	25	1" ANSI	0,75
LK50	330	18	1" ANSI	0,75
LK65	230	15	1" ANSI	0,75
LK65	560	11	1" ANSI	0,75
LK80	520	10	1" ANSI	0,75
LK80	1050	5,5	2" ANSI	0,75

\* Typical performances based on both 50 and 60 Hz.

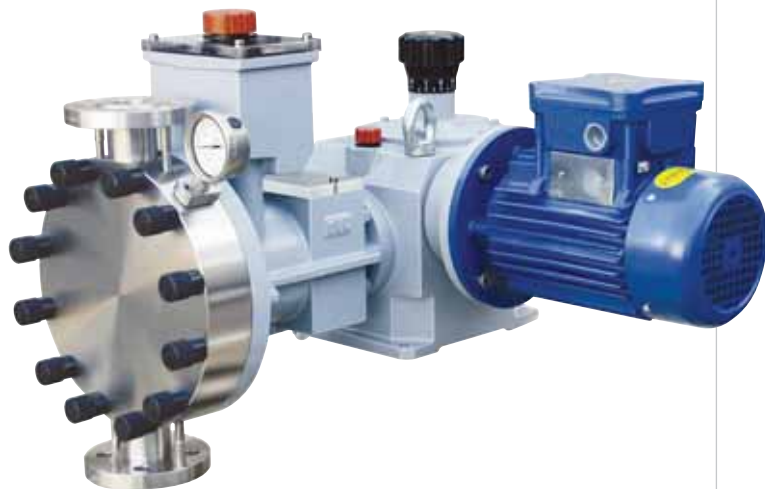

LK X9A series process diaphragm metering pump with AISI 316L pump head.

# LK 1050l/h

- Flow rates:**
  - Max flow rate **1050 L/h**
- Motors:**
  - 0,37 kW - 0,75 kW
- Pump:**
  - Single and multiple
- Adjustment:**
  - Manual and automatic
- Casing material:**
  - Cast iron
- Stroke:**
  - 30 mm.
- Strokes/1':**
  - 42-60-82-102-123
- App. Weighth:**
  - 40÷70 Kgs

## MATERIALS OF CONSTRUCTIONS

WETTED PARTS	X9 A	X9 P
LIQUID END	AISI 316L	PVC
VALVE	AISI 316L	PIREX
VALVE SEAT	AISI 316L	PVC
VALVE GUIDE	AISI 316L	PVC
VALVE SEAL	FPM	FPM
DIAPHRAGM	PTFE	PTFE

## MAX OVERALL DIMENSIONS

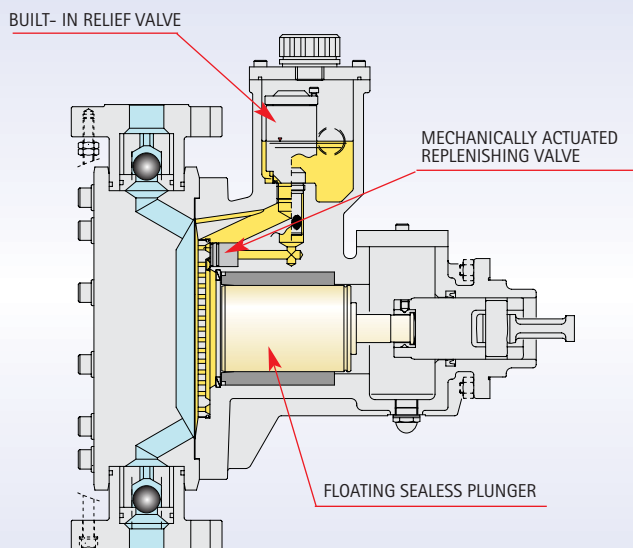
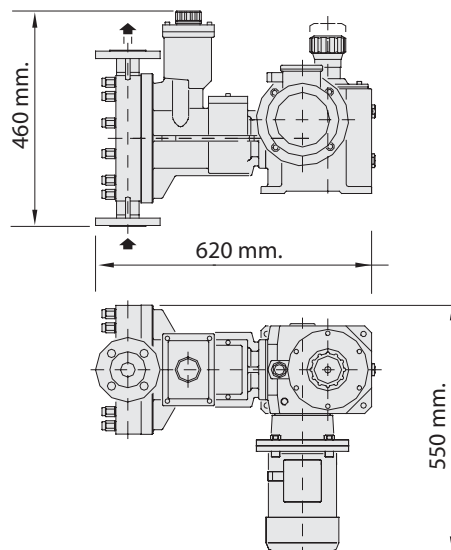

LK X9 type.

# LN X9 Technical data

TYPE	FLOW RATE l/h *	MAX PRESS. BAR	FLANGED CONNECTIONS	kW
LN25	60	100	3/4" ANSI	1,5
LN25	160	80	3/4" ANSI	1,5
LN30	105	90	3/4" ANSI	1,5
LN30	230	60	3/4" ANSI	1,5
LN40	190	50	1" ANSI	1,5
LN40	415	32	1" ANSI	1,5
LN50	295	35	1" ANSI	1,5
LN50	648	25	1" ANSI	1,5
LN65	500	22	1 1/2" ANSI	1,5
LN65	1050	16	1 1/2" ANSI	1,5
LN80	930	15	1 1/2" ANSI	1,5
LN80	1660	8	1 1/2" ANSI	1,5
LN100	1450	8	1 1/2" ANSI	1,5
LN100	2600	5	2" ANSI	1,5

\* Typical performances based on both 50 and 60 Hz.



LN X9A series process diaphragm metering pump with AISI 316L pump head.



- Flow rates: • Max flow rate **2600 L/h**
- Motors: • 1,5 kW - 2,2 kW
- Pump: • Single and multiple
- Adjustment: • Manual and automatic
- Casing material: • Cast iron
- Stroke: • 50 mm.
- Strokes/1': • 56-68-80-96-120
- App. Weigth: • 150 Kgs

### MATERIALS OF CONSTRUCTIONS

WETTED PARTS	X9 A	X9 P
LIQUID END	AISI 316L	PVC
VALVE	AISI 316L	PIREX
VALVE SEAT	AISI 316L	PVC
VALVE GUIDE	AISI 316L	PVC
VALVE SEAL	FPM	FPM
DIAPHRAGM	PTFE	PTFE

### MAX OVERALL DIMENSIONS

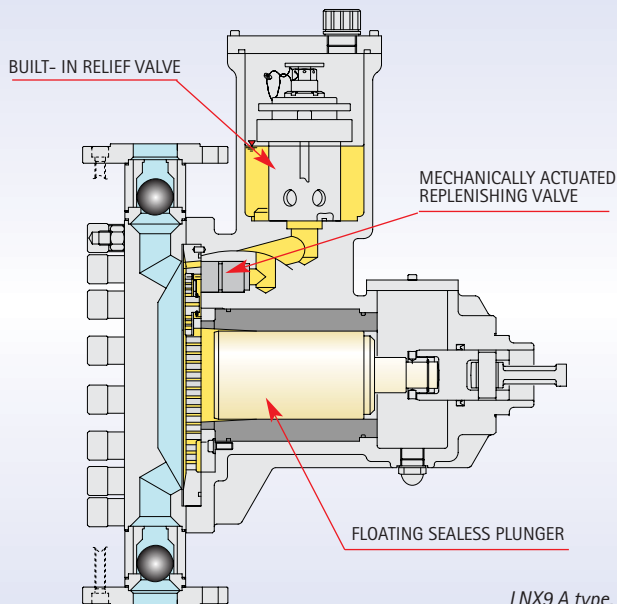
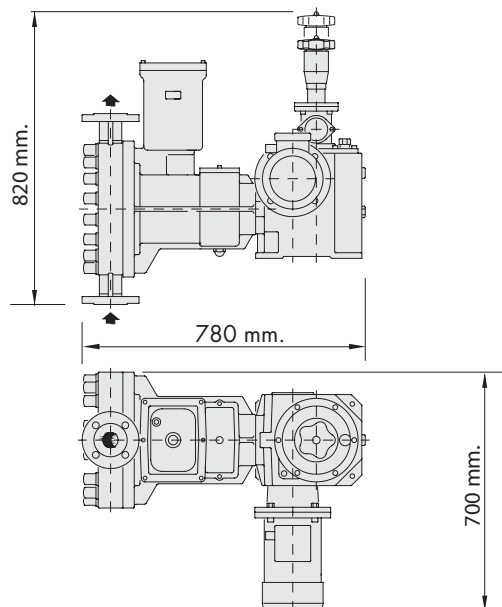

LN X9A type.

# LP X9 *Technical data*

TYPE	FLOW RATE l/h *	MAX PRESS. BAR	FLANGED CONNECTIONS	kW
LP30	90	100	3/4" ANSI	4
LP30	235	100	3/4" ANSI	4
LP40	190	100	1" ANSI	4
LP40	415	80	1" ANSI	4
LP50	295	60	1" ANSI	4
LP50	650	48	1" ANSI	4
LP65	500	40	1 1/2" ANSI	4
LP65	1095	30	1 1/2" ANSI	4
LP80	930	25	1 1/2" ANSI	4
LP80	1660	18	1 1/2" ANSI	4
LP100	1450	15	1 1/2" ANSI	4
LP100	2590	11	2" ANSI	4
LP120	2090	10	2" ANSI	4
LP120	3730	8	2" ANSI	4

\* Typical performances based on both 50 and 60 Hz.



LP X9A series process diaphragm metering pump with AISI 316L pump head.



- Flow rates:**
  - Max flow rate **3730 L/h**
- Motors:**
  - 3 kW - 4 kW
- Pump:**
  - Single and multiple
- Adjustment:**
  - Manual and automatic
- Casing material:**
  - Cast iron
- Stroke:**
  - 50 mm.
- Strokes/1':**
  - 56-68-82-97-120
- App. Weighth:**
  - 170 Kgs

### MATERIALS OF CONSTRUCTIONS

WETTED PARTS	X9 A	X9 P
LIQUID END	AISI 316L	PVC
VALVE	AISI 316L	PIREX
VALVE SEAT	AISI 316L	PVC
VALVE GUIDE	AISI 316L	PVC
VALVE SEAL	FPM	FPM
DIAPHRAGM	PTFE	PTFE

### MAX OVERALL DIMENSIONS

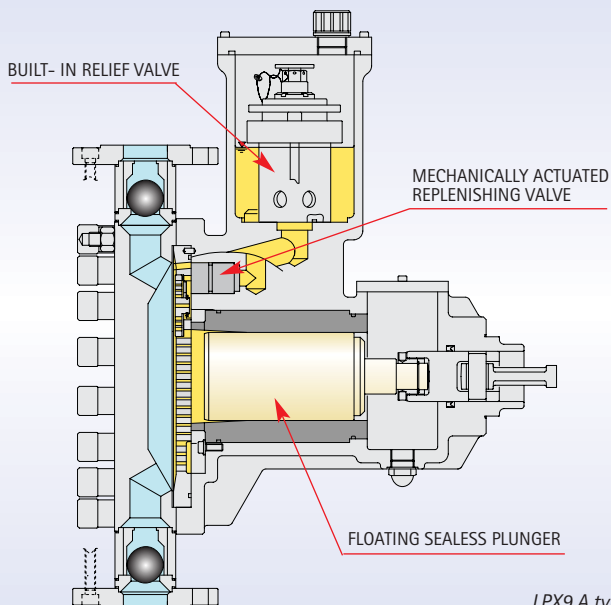
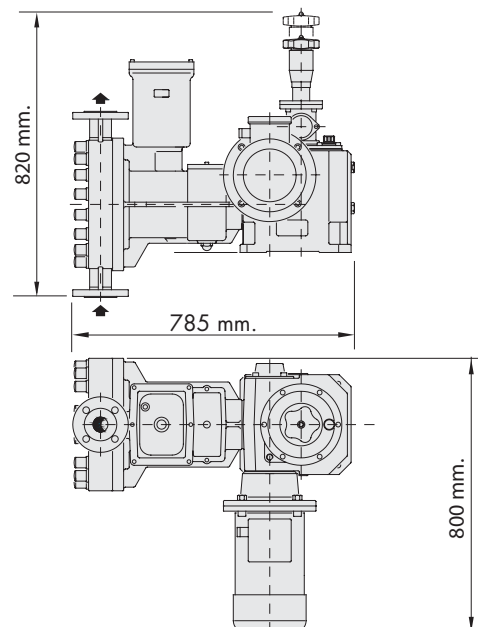

LPX9 A type.



**TS** High pressure

4-headed LPX9ATS for demulsifier injection at 128 bar g, being used at topsides process and facilities modules off-shore Australia (FPSO).



# HIGH PRESSURE

## Technical data

TYPE	FLOW RATE l/h *	MAX PRESS. BAR	CONNECTIONS		KW
			THREADED	FLANGED	
LYH10	2,5	250	1/2" NPT F	1/2" ANSI1500RF	0,37/0,75
LYH10	4	250	1/2" NPT F	1/2" ANSI1500RF	0,37/0,75
LYH10	6	250	1/2" NPT F	1/2" ANSI1500RF	0,37/0,75
LYH10	7	200	1/2" NPT F	1/2" ANSI1500RF	0,37/0,75
LK10	3	300	1/2" NPT F	1/2" ANSI900/1500RF	0,75
LK10	4	300	1/2" NPT F	1/2" ANSI900/1500RF	0,75
LK10	5	300	1/2" NPT F	1/2" ANSI900/1500RF	0,75
LK10	7	300	1/2" NPT F	1/2" ANSI900/1500RF	0,75
LK15	9	300	1/2" NPT F	1/2" ANSI900/1500RF	0,75
LK15	11	300	1/2" NPT F	1/2" ANSI900/1500RF	0,75
LK15	14	270	1/2" NPT F	1/2" ANSI900/1500RF	0,75
LK15	18	250	1/2" NPT F	1/2" ANSI900/1500RF	0,75
LK15	22	235	1/2" NPT F	1/2" ANSI900/1500RF	0,75
LK20	22	170	1/2" NPT F	1/2" ANSI900/1500RF	0,75
LK20	27	170	1/2" NPT F	1/2" ANSI900/1500RF	0,75
LK20	32	160	1/2" NPT F	1/2" ANSI900/1500RF	0,75
LK20	42	150	1/2" NPT F	1/2" ANSI900/1500RF	0,75
LK20	52	140	1/2" NPT F	1/2" ANSI900/1500RF	0,75
LN20	30	220	1/2" NPT F	1/2" ANSI1500RF	1,5
LN20	35	220	1/2" NPT F	1/2" ANSI1500RF	1,5
LN20	43	220	1/2" NPT F	1/2" ANSI1500RF	1,5
LN20	54	200	1/2" NPT F	1/2" ANSI1500RF	1,5
LN20	63	200	1/2" NPT F	1/2" ANSI1500RF	1,5
LN20	80	180	1/2" NPT F	1/2" ANSI1500RF	1,5
LN20	100	160	1/2" NPT F	1/2" ANSI1500RF	1,5
LN25	120	110	1/2" NPT F	1/2" ANSI900RF	1,5
LN25	150	100	1/2" NPT F	1/2" ANSI900RF	1,5
LP20	30	350	1/2" NPT F	1/2" ANSI2500RF	3-4
LP20	35	350	1/2" NPT F	1/2" ANSI2500RF	3-4
LP20	42	350	1/2" NPT F	1/2" ANSI2500RF	3-4
LP20	52	350	1/2" NPT F	1/2" ANSI2500RF	3-4
LP20	60	350	1/2" NPT F	1/2" ANSI2500RF	3-4
LP20	76	330	1/2" NPT F	1/2" ANSI2500RF	3-4
LP20	95	310	1/2" NPT F	1/2" ANSI2500RF	3-4
LP25	120	220	1/2" NPT F	1/2" ANSI1500RF	3-4
LP25	150	200	1/2" NPT F	1/2" ANSI1500RF	3-4
LP30	130	185	3/4" NPT F	3/4" ANSI1500RF	3-4
LP30	153	170	3/4" NPT F	3/4" ANSI1500RF	3-4
LP30	185	155	3/4" NPT F	3/4" ANSI1500RF	3-4
LP30	230	140	3/4" NPT F	3/4" ANSI1500RF	3-4

\* Typical performances based on both 50 and 60 Hz.

### MATERIALS OF CONSTRUCTIONS

WETTED PARTS	LYH X9 AA	LK-LN-LP X9 A
LIQUID END	AISI 316L	AISI 316L
VALVE	RUBY	AISI 316L
VALVE SEAT	CERAMIC	AISI 316L
VALVE GUIDE	AISI 316L	AISI 316L
VALVE SEAL	FPM	FPM
DIAPHRAGM	AISI 316L	PTFE



## Pump heads

Pump heads, designed for 24/7 high pressure severe duties, have the following characteristics:

- Pump heads are locked onto hydraulic chambers by tie rods and cap nuts.
- Valve assemblies are locked onto pump heads by ring nuts.
- Solid, floating, sealless, ceramic, oil bathed plunger.
- Either ceramic or AISI 316L lapped valve seats.
- Metallic diaphragms for high accuracy below 7 l/h.
- RTJ#1500-2500 flanged connections (on demand).

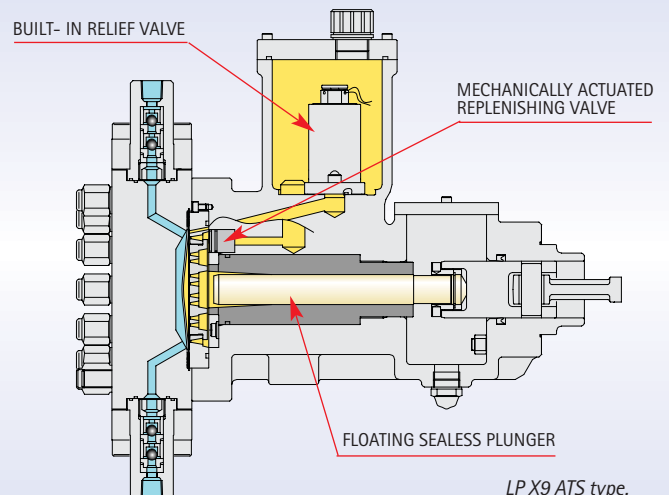

LP X9 ATS type.

**Electric actuators Z type** >

X9 series, as all OBL pumps, can be equipped with Z type electrical actuator, with following characteristics:

- IP 66 STD
- Manual emergency override
- Anticondensation heater (on demand)
- Non standard voltages and frequencies
- External automatic/manual selector

Flow rate is adjusted according to following input signals:

- 4-20 mA, 0-20 A, 20-4 mA e 0-10 V
- Pulses (0÷2 Hz - 0÷30 Hz)
- RS 485 protocol
- PROFIBUS DP



**Electric actuators** >

- ATEX II 2GD EEx-d IIB T4 IP6X
- 115/230V - 1 - 50/60 Hz
- 4-20 mA signal and feedback
- Manual emergency override
- Anticondensation heater (on demand)



**Pneumatic actuator W type** >

- ATEX II 2G c IIC T6
- Pneumatic actuator type WA.
- Air instrument 3÷15 PSI
- Air supply 4-6 bar
- Emergency manual override



**Manual actuator** >

0÷100% manual adjustment via:

- Knob with micrometer scale.
- Gravitational dial handwheel.

Knob with micrometer scale.



Gravitational dial handwheel.



## X9 References

Year	End user / contractor / Customer	Plant type	Country
2010	Staoil Hydro/Akersolutionsas	Oil&Gas (Kollsnes kop plant)	Norway
2010	Bechtel Power Division (TVA)	Power Gen Nuclear	USA
2010	Repsol	Refinery	Spain
2010	Tupras	Refinery	Turkey
2010	Tuapsinky NPZ Rosneft	Refinery	Russia
2010	Sasol	Refinery	South Africa
2009	Qatalum (JV Qatar Petroleum&Norsk Hydro As)	Cooling tower	Qatar
2009	PDO/Mott Mac Donald&Co LLC	Petrochemical	Oman
2009	YPF Petroquimica	Petrochemical	Argentina
2009	Bahia Las Minas/Sadelmi	Power station	Panama
2009	Staoil Hydro	Oil&Gas	Norway
2008	Petrobel	Oil&Gas	Egypt
2008	Qatar EL&Water Fisia Italimpianti	Power station	Qatar
2008	Mol PLC	Petrochemical	Hungary
2008	Dalian Chem Corp	Plastic Ind	Taiwan
2008	Pequiven SA	Chemical	Venezuela
2008	Repsol-YPF	Petrochemical	Spain
2008	Pluspetrolperu-Techint	Oil&Gas	Peru
2008	ICT Poland	Pulp&Paper production	Poland
2008	Proxital	Liquefied gases dosing for expanded materials	Italy
2008	Desmet Ballestra	Biodiesel production plant	Spain
2008	Tamoil SA, Collombe refinery	Petrochemical	Switzerland
2008	Formosa Plastic Corporation	Petrochemical	Taiwan
2008	Repsol YPF	Petrochemical	Argentina
2007	SARAS SpA /Foster-Wheeler Italy	Petrochemical	Italy
2007	PETROJET	WWTP	Egypt
2007	TECNA SA/Total Carina Aires	Off-shore platform	Argentina
2007	Black and Veatch / 4D - Southern water	WWTP, methanol injection	UK
2007	Desmet-Ballestra	Biodiesel production plant	Spain
2007	MINERA ESCONDIDA - BHP Billiton	Copper ore production (mining)	Chile
2007	Hillsborough County (Florida)	Effluent WWTP	USA
2007	Uniens Co. Ltd	WWTP, Hochimin City	Vietnam
2007	Skikda	Desalination plant	Algeria
2006	VETCO Aibel AS/Maersk, Wooside Energy Ltd	FPSO	Australia
2006	Samsung /Linde Engineering /Tasnee Petrochemicals	Ethylene project, Al-Jubail	Saudi Arabia
2006	VETCO Aibel AS /Bluewater Energy service (BES)	FPSO	UK, North sea
2006	Bechtel-Conoco Philipps	Darwin LNG project	Australia
2006	BP Oil /Intecsa	Petrochemical	Spain
2006	DODSAL/Abu Dhabi Oil refining Co (TAKREER)	Inter refineries pipelines (IRP) project	UAE
2006	ERG Raffinerie Mediterranee	Petrochemical	Italy
2006	Kellog Brown & Root SVCS Inc.	Deminalisation	Iraq
2005	Agip Kazakhstan North Caspian Operating Co.	Kashagan field petrochemical development	Kazakhstan
2005	BASF-YPC Company Ltd	Ethylene plant	China PR
2005	Repsol-YPF	HTFNCC Project	Argentina
2005	Aker-Kverner/STATOIL	Oppgradering AV NPU, offshore platform Snorre A (TLP)	Norway
2005	Nan Ya Plastics Corp.	Plastic production	Taiwan
2005	Worley Engineering	SPI Electricicy Casan project, gas plant	Australia
2005	Dalian Chemical Corp.	BD03/PTG3 chemical plant project	China PR
2005	Bechtel Marathon Oil Company	Alba Phase 3 project, petrochemical	Equatorial Guinea
2005	Thai Petrochemical Industry, Polyol Co. Ltd	Polymer production	Thailand
2004	TOYO Engineering & Construction	SCNP project	China PR
2004	PT. Trans-Pacific Petrochemical Indotama	Refinery	Indonesia
2004	Formosa Chemical and fibres corporation	Chemical production	Taiwan
2004	Nubaria power plant	West delta electricity production	Egypt
2004	JGC Corporation/Sohar refinery company LLC	Refinery	Oman
2004	Bechtel_Phillips Petroleum Company	Darwin LNG Project	Australia
2004	DOOSAN Heavy Industries and Construction Ltd	Combined cycle power station	Jordan
2004	ENERCAL, Doniambo Power station	High pressure boiler dosing	New Caledonia
2003	PT. INTI KARYA PERSADA TEHNICK	Ammonia Urea Project	West Java, Indonesia
2003	Akzo Nobel AB Godsmottagning	ETEK Pilot plant	Sweden
2003	Agip Kazakhstan North Caspian Operating Company	Refinery	Kazakhstan
2003	AKERKVERNER	Oil&Gas	Norway



> > Studio\_SCAFIDI\_Comunicazioni\_Visive



**OBL s.r.l.**

20090 Segrate - MILANO

Via Kennedy, 12

Tel. +39-02.269191

Fax +39-02.2133893

[www.oblitalia.com](http://www.oblitalia.com)

[obl.info@idexcorp.com](mailto:obl.info@idexcorp.com)