

## PULSATron® X

When safety, compliance, and reliability matter the Pulsatron X Explosion Proof metering pump provides safe feed of chemical into your process. The hazardous location ratings of Pulsatron X indicate its exceptional durability to manage internal explosions, enabling dependable and accurate chemical metering in a secure and reliable manner. Available with either a 4-20mA input or an external pulse input the Pulsatron X is ideal for applications that require remote control of the dosing rate. The Pulsatron X rugged, cast aluminum housing was designed for high corrosion resistance and integrated inputs into the control panel of the pump eliminating the need for an extra device and external enclosures.



### FLOW

up to 600 GPD (94.6 LPH)



### PRESSURE

up to 300 PSIG (21 BAR)

## FEATURES

### EXPLOSION PROOF

- Hazardous location rating, for facilities that deal with hazardous material in the environment such as flammable gases and dust particles

### ALUMINUM HOUSING

- Rugged, corrosion resistant housing for corrosive chemical applications

### INTEGRATED INPUTS

- Eliminating an extra device and external enclosure

### AUTOMATIC CONTROL

- 4-20mA input
- External pulse input with stop

### 4-20MA INPUT OR AN EXTERNAL PULSE INPUT

- Remote control of the dosing rate

### MANUAL CONTROL

- On-line adjustable stroke rate and stroke length

### GUIDED BALL CHECK VALVE SYSTEM

- Reduce back flow and enhance outstanding priming characteristics

### DURABLE LEAK FREE BLEED VALVE ASSEMBLY

- Safe and easy priming

### SIMPLE SUBSTITUTION OF COMPETITORS IN THE FIELD

- No need to re-drill mounting holes

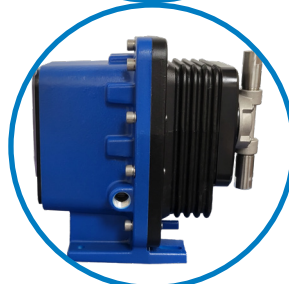

## CONTROLS

### MANUAL STROKE RATE

- Turn-Down Ratio 10:1

### MANUAL STROKE LENGTH

- Turn-Down Ratio 10:1

### 4-20MADC DIRECT OR EXTERNAL PACING WITH STOP

- Automatic Control

Tested and Certified by WQA against NSF/ANSI/CAN 61 & 372.



Intertek  
9700150



PVDF & PVC Degass Head Pumps.  
See [www.wqa.org](http://www.wqa.org) for certification parameters.

## SPECIFICATIONS

MODEL		XPk4	XPk5	XPk6	XPk7	XPk8
Capacity nominal (max.)	GPH	1.30	3.15	5.00	10.00	25.00
	GPD	31	76	120	240	600
	LPH	4.9	11.9	18.9	37.9	94.6
Pressure (max.)	PSIG	300	150	100	80	30
	BAR	21	10	7	5.5	2
Connections	Tubing	1/4" ID X 3/8" OD	3/8" ID X 1/2" OD			1/2" ID X 3/4" OD
	Piping		1/4" FNPT			1/2" FNPT

## ENGINEERING DATA

Pump Head Materials Available	GFPPL, PVC, PVDF, 316 SS
Diaphragm	PTFE-faced CSPE-backed
<b>Check Valves Materials Available</b>	
Seats/O-Rings	PTFE, CSPE, Viton
Balls	Ceramic, PTFE, 316 SS, Alloy C
Fitting Materials Available	GFPPL, PVC, PVDF
Bleed Valve	Same as fitting and check valve selected
Injection Valve & Foot Valve Assy	Same as fitting and check valve selected
Tubing	Clear PVC, White PE
Reproducibility	±2% a maximum capacity
Viscosity Max CPS	1000 CPS*
Rating	"Hot" for continuous duty

\*For viscosity up to 3000 CPS, select connection size 3, 4, B or C with 316SS ball material. Greater than 3000 CPS require spring loaded ball checks. Flow rate will determine connection/ball size. See Selection Guide for proper connection.

Stroke Frequency Max SPM	125
Stroke Frequency Turn-Down Ratio	10:1
Stroke Length Turn-Down Ratio	10:1
Power Input	115 VAC / 50-60 HZ / 1 ph
	230 VAC / 50-60 HZ / 1 ph
<b>Average Current Draw</b>	
@ 115 VAC: Amps	1.5 Amps
Peak Input Power	460 Watts
Average Input Power @ Max SPM	190 Watts
Ambient Temperature Range	32°F to 122°F (0°C to 50°C)
Approvals	Conforms to NSF/ANSI/CAN 61 & 372 (PVDF models are 61) Class I, Div 1, Groups C, D, T5 Class I, Zone 1, Group IIB T5

Important: Material Code - GFPPL=Glass-filled Polypropylene, PVC=Polyvinyl Chloride, PE=Polyethylene, PVDF=Polyvinylidene Fluoride, CSPE=Generic formulation of Hypalon, a registered trademark of E.I. DuPont Company. Viton is a registered trademark of E.I. DuPont Company. PVC wetted end recommended for sodium hypochlorite.

## DIMENSIONS

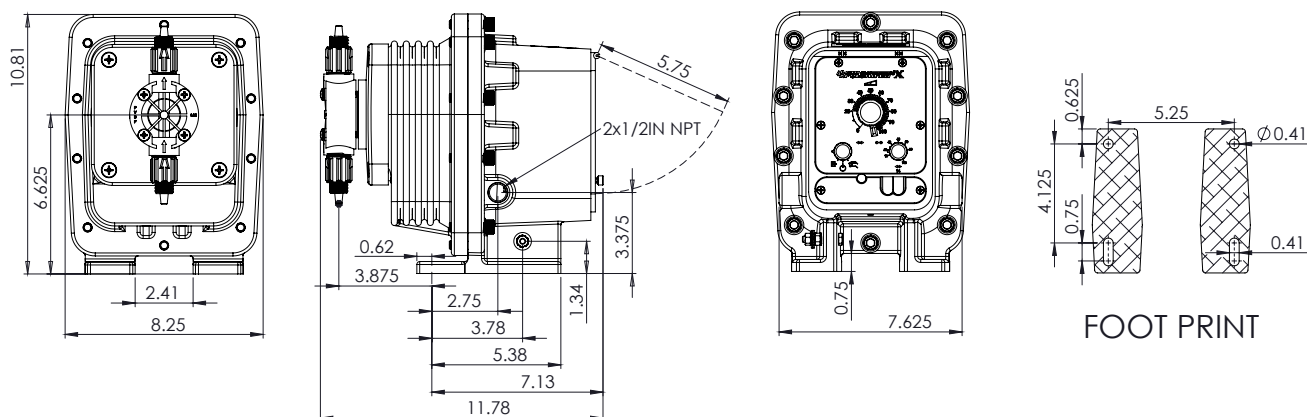

The dimensions given do not include bleed valve.  
Approximate weight 50 lbs

**PULSAFEEDER**

[info@abmoli.com](mailto:info@abmoli.com)  
[WWW.ABMOLI.COM](http://WWW.ABMOLI.COM)

הנגר 3 כפר סבא Hanagar 3 Kfar saba  
P.O.B 2003 ת.ד.  
טל. 09-7434264  
פקס 09-7440681

**IBEX**  
EMP019 D24